



## Aventa comfort (Australia)

**AUS** Operation instructions  
instructions Page 9

Page 2 Installation

To be kept in the vehicle!

**Table of contents**

Symbols used ..... 3  
**Safety instructions** ..... 3  
**Instructions for using [air conditioning units](#)** ..... 3

**Operating instructions**

Remote control ..... 4  
 Taking into operation ..... 5  
 Switching on ..... 5  
 Mode ..... 5  
 Fan ..... 5  
 Sleep function ..... 5  
 Switching off ..... 5  
 Time ..... 5  
 Timer ON / OFF ..... 5  
 Ambient lighting ..... 5  
 Reset ..... 5  
 Resend ..... 5  
 IR receiver and manual on / off ..... 6  
 IR receiver / operating indicator ..... 6  
 Red LED illuminates ..... 6  
 Air distribution ..... 6  
 Changing the battery in the IR remote control ..... 6  
**Maintenance** ..... 6  
**Disposal** ..... 6  
**Accessories** ..... 6  
**Troubleshooting** ..... 7  
**Technical data** ..... 7  
 Installation dimensions (dimensions in mm) ..... 7  
 Clearance around the air conditioning system ..... 8  
 Air inlets / Air outlets ..... 8  
 Condensation traps ..... 8  
**Declaration of conformity** ..... 8  
**Truma warranty policy** ..... 9

**Installation instructions**

Scope of delivery ..... 9  
 Intended use ..... 9  
**Location selection** ..... 9  
**Installation in a 400 x 400 cut-out** ..... 10  
**Installation in a new cut-out** ..... 10  
 Preparation for mains cable connection ..... 10  
 Fixing the unit in place ..... 10  
 Installing roof thickness adapters ..... 11  
 Fixing the air distributor in place ..... 11  
 Installing filters ..... 11  
 230 V electrical connection ..... 11  
 Function test / Mounting for the remote control ..... 11

## Symbols used



Symbol indicates potential dangers.



Note with information and tips.

## Safety instructions



All repairs must be carried out by an expert!

In order to avoid transport damage, the unit may only be dispatched after consulting the Truma Service Centre.

The voltage must be disconnected from the mains (all poles) before opening the housing.

Device fuses and connecting cables must only be replaced by experts.

The 230 V, T 6.3 A H-type (slow) fuse in the unit can be found on the electronic control unit and must always be replaced with an identical fuse.

Guarantee claims, warranty claims and acceptance of liability will be ruled out in the event of the following:

- modifications to the unit (including accessories),
- failure to use original Truma parts as replacement parts and accessories,
- failure to follow the installation and operating instructions.

The refrigerant circuit contains R 407C refrigerant and must only be opened **in the factory**.

The air inlets/air outlets on the outer unit and on the air distributor must not be obstructed under any circumstances. Compliance with this requirement is vital in order to ensure that your unit operates correctly.

In order to avoid damage to the compressor, when the device is in operation during transit (for example, with the generator or voltage transformer working), do not attempt uphill or downhill gradients of more than 8 %.

Do not allow cooling operation to run for extended periods in a tilted position, since the condensation water which forms may not be able to run off, and in the worst scenario might penetrate into the vehicle.

For problem-free operation and in order to avoid damage, the supply voltage must always come from a source with a sine wave curve (e.g. voltage converter, generator) and without voltage spikes.

When the vehicle is being cleaned (with a high-pressure cleaner, for example), make sure that no water can get in to the unit (do not spray directly into the openings of the unit, for example).

The use of high-temperature cleaners and steam cleaners is **not** permitted.

The condensation traps must not be obstructed at any time during operation.

## Instructions for using air conditioning units

The air conditioning unit is designed for power consumption of up to 4.2 A. Before switching on, it is essential to make sure that the fuse system for the power supply at the camp site is sufficient (min. 6 A).

As far as possible, park your vehicle in the shade.

Darkening the vehicle with blinds will reduce the penetration of radiant heat.

Clean the roof of the vehicle regularly (dirty roofs heat up more readily).

Before operating the device, ventilate your vehicle thoroughly, in order to allow the hot air which builds up inside to escape.

To create a healthy environment on the inside of the vehicle, the difference between the inside and outside temperatures should not be selected as too great. During operation the circulated air will be purified and dried. Due to the drying of the moist, humid air, a pleasant environment will be created inside even with slight temperature differences.

Keep the doors and windows closed while the cooling system is in operation.

For rapid cooling or heating:

- Set the fan level to high
- Set the air distributor for the front/rear to medium
- Set the air distributor for the floor/ceiling to ceiling

## Operating instructions

### Remote control



The symbols shown on the display become visible depending on the setting.

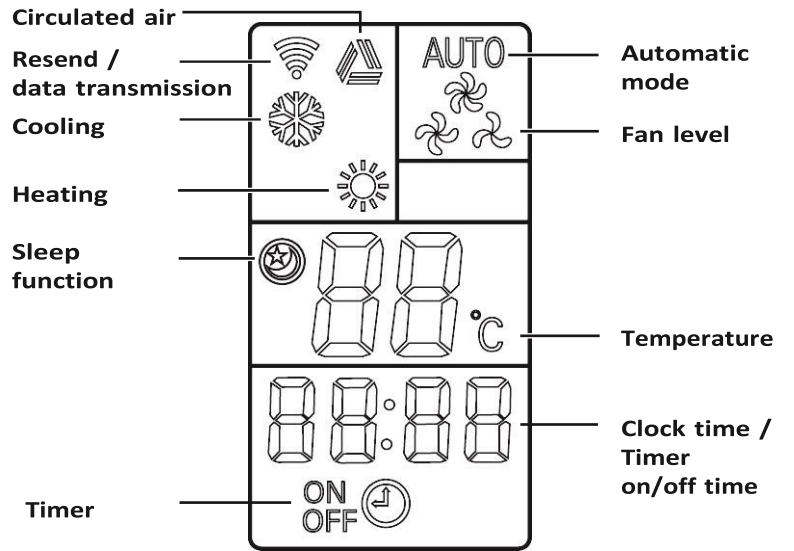

**Mode**

Operating mode selection button  
 – Cooling  
 – Heating  
 – Automatic  
 – Circulated air

**Fan level**

– Low  
 – Medium (not heating mode)  
 – High

**Clock time selection button**

**Sleep function**

(cooling mode only)  
 Extremely quiet fan operation thanks to a reduction in the speed of both fans

**Ambient lighting**

The lighting is dimmed by pressing and holding down the button. Pressing it again deactivates or activates the lighting.

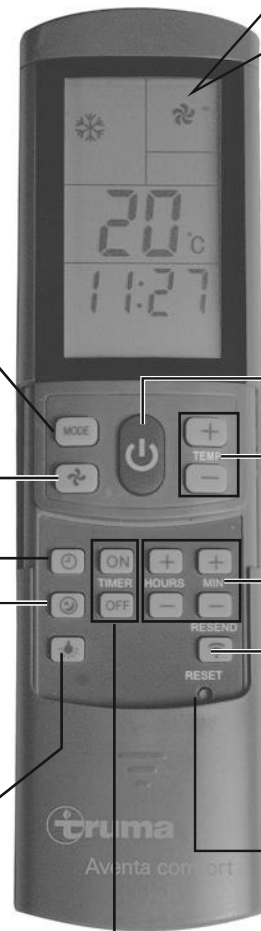

**On/off switch**

**Temperature selection buttons**  
 16 – 31 °C  
 In 1°C increments

**Time setting**  
 Setting for clock time and timer

**Resend**  
 Retransmit data

**Reset**  
 Restores the remote control to its factory settings.

**Timer selection buttons**

Switch-on or switch-off time can be set up to 24 hours in advance

**Taking into operation**

Before switching on, it is essential to make sure that the fuse system for the power supply at the camp site is sufficient (230 V).



In order to prevent the power cable for the caravan from overheating (minimum cross-section 3 x 2.5 mm<sup>2</sup>) the cable drum must be fully unwound.

To carry out the individual switching commands, the remote control must always be pointed at the infrared receiver.

## Switching on

Press the **“On/Off switch”** on the remote control to switch on the air conditioning unit. The most recent settings are applied.



After switching on, the air circulation fan starts to run. The compressor activates after a maximum of 3 minutes, and the blue (cooling) / yellow (heating) LED flashes.

## Temperature

If required, adjust the room temperature setting using the **“+”** and **“-”** **“Temperature selection buttons”**.

## Mode

Select the required operating mode by pressing the **“MODE”** button one or more times.

- Cooling
- Heating
- Automatic (heating or cooling mode depending on the room temperature setting)
- Circulated air

When the room temperature that was selected using the remote control is reached in **cooling mode**, the compressor switches off and the blue LED in the IR receiver goes out. The air circulation fan continues to run in order to provide ventilation. If the room temperature setting is exceeded, the device automatically reverts to cooling mode.

When the room temperature that was selected using the remote control is reached in **heating mode**, the compressor switches off and the yellow LED in the IR receiver goes out. The air circulation fan continues to run in order to provide ventilation. If the temperature drops below the room temperature setting, the device automatically reverts to heating mode.



Heating is not possible at an outside temperature of less than 4 °C, as the heating power drops significantly. Between 4 °C and 7 °C the device briefly switches to thawing processes. Heating is possible without restrictions above 7 °C.

Cooling/heating mode and the fan level are selected automatically depending on the room temperature when the unit is in **automatic mode**.

In **recirculated air mode**, the interior air is circulated and cleaned by the filters. No LED's illuminate on the IR receiver.

## Fan

Select the required fan level by pressing the **“Fan level”** button one or more times.

- **Fan level** (not operational in automatic mode)
- Low
- Medium (not heating mode)
- High

## Sleep function

When the **“Sleep function”** is active (cooling mode only), the interior fan and the exterior fan operate at slow speed and therefore extremely quietly.

## Switching off

Press the **“On / Off”** button on the remote control to switch the equipment off. The remote control and the unit are switched off. The light can still be operated using the **“Ambient lighting”** button.



If the air conditioning unit is switched on again, the blue / yellow LED flashes. The air circulation fan runs and the compressor switches itself on after a maximum of 3 minutes.

## Time

Press the **“Time selection button”** and set the current time using the **“Time setting”** buttons.

The time is always shown in the display (except with Timer ON / OFF).

The time must be reset after a battery change or daylight saving time change.

## Timer ON / OFF

The air conditioning unit on/off time can be set in advance from a minimum of 15 minutes up to a maximum 24 hours, starting from the current time.

To carry out programming, switch on the unit with the remote control.

Set the required operating mode and room temperature.

Then select TIMER ON or TIMER OFF using the **“TIMER selection buttons”**. Set the required on/off time using the **“Time setting”** buttons (15 minutes – 24 hours) and **confirm** with TIMER ON or TIMER OFF.

Press the relevant timer button again to deactivate the timer function.

## Ambient lighting

Independently of the operation of the air conditioning system, the lighting in the air distributor can be switched on and off by pressing the **„Ambient lighting“** button. To dim the lighting, press and hold down the **“Ambient lighting”** button. Press the button again to activate or deactivate the lighting. When the lighting is switched on again, the previous setting is activated.

## Reset

The settings on the remote control are reset to **“AUTO, 22 °C, 12:00, No timer, No light”**.

## Resend

The most recent settings are transmitted again.

## IR receiver and manual on / off

There is an additional pushbutton on the receiver (m), with which the unit can also be switched on and off without the remote control (e.g. with a ballpoint pen).

If the unit is switched on using this pushbutton, the system is automatically reset to the factory settings (Automatic mode, 22 °C).

## IR receiver / operating indicator

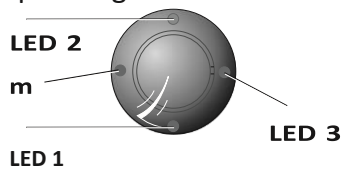

- LED 1 blue – permanently on – (cooling mode)
- LED 1 blue – flashing – (cooling mode compressor start-up)
- LED 2 yellow – permanently on – (heating mode)
- LED 2 yellow – flashing – (heating mode compressor start-up)
- LED 3 red – flashing – (data is being transmitted)
- LED 3 red – permanently on – (fault)

## Red LED illuminates

The unit is indicating a fault. Switch unit off, wait for a short time and switch on again. If the red LED continues to illuminate, please contact Truma Service.

## Accessories

### Air distribution

#### Right / left

Two individually adjustable air outlets at the front, and two at the rear.

#### Front / rear

The air flow can be split so that specific quantities are fed into the front and rear areas of the vehicle.

#### Ceiling / floor

The air flow can be deflected from the ceiling to the floor.

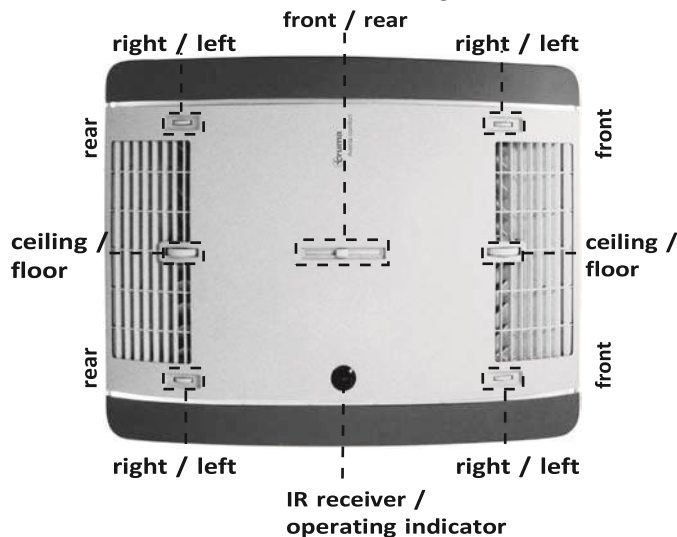

## Changing the battery in the IR remote control

Please be sure to use leak-proof micro-batteries only, type LR 3, AM4, AAA, MN 2400 (1.5 V).

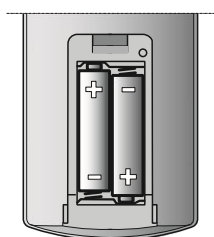

The battery compartment is located on the rear of the remote control unit.

When fitting new batteries, ensure the polarity (positive/negative) is correct!

Dead and used batteries may leak and damage the remote control

unit. Remove the batteries if the remote control is not going to be used for an extended period.

**No claims under guarantee will be considered for damage caused by leaking batteries.**

Before throwing away a defective remote control, it is essential that the batteries be removed and disposed of in the proper manner.

## Maintenance

Filter changes should be carried out depending on the amount of use, but we recommend a change at least every 12 months. Never operate the air conditioning system without a filter, since this can decrease performance. Always keep the air inlets / air outlets and condensation traps on the roof free from obstructions such as leaves. Use a soft, clean cloth to clean the air conditioning system.

## Disposal

The device must be disposed of in line with the administrative

## Technical data

regulations of the respective country in which it is used. National regulations and laws (in Germany, for example, the End-of-life Vehicle Regulation) must be observed.

In other countries, the relevant regulations must be observed.

Filter set, 2 x (part no. 40091-16800)



10 mm roof thickness adapter, 1 x (part no. 40091-16900)



Sealing frame (part no. 40091-19500) recommended for optimum sealing in the case of retrofitting in vehicles with cut-outs measuring 400 x 400 mm.

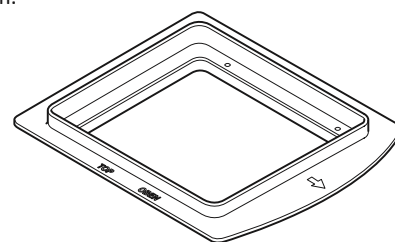

## Troubleshooting

Fault	Cause / Action
Unit not cooling	– Thawing process in progress – The temperature set on the remote control has been reached or is too high

- Unit not heating
  - Thawing process in progress (outside temperature between 4 °C and 7 °C)
  - Outside temperature below 4 °C
- Unit underperforming or failing in cooling / heating mode
  - Filter soiled, replace filter
  - Air ways to the outside soiled / blocked
  - Close windows and doors and set the fan level to high
- Moisture on the underside of the air distributor
  - Condensation trap on external unit blocked
  - No proper seal between unit and roof (e.g. faulty seal)
  - Angle of tilt of system too great
- Water dripping out of air distributor
  - Check remote control batteries and replace if necessary
  - Check for obstructions between remote control and IR receiver
- Remote control not working
- Unit not responding to remote control commands

**Should these actions not resolve the corresponding problem, please contact Dometic Service.**

**Power supply**

230 V – 240 V~, 50 Hz

**Current consumption** Cooling: 4.2 A

Heating: 3.7 A

**Start-up current**

28 A (150 ms)

**Cooling power**

2.4 kW

**Heating power**

1.7 kW (heat pump)

**Volumetric air flow**

Max. 400 m<sup>3</sup>/h

**Operational limits**

+4 °C to 40 °C

**Maximum tilt during operation**

8 %

**Weight**

33.5 kg plus installation materials **Dimensions (W x H x D)**

External: 660 x 248 x 1008 mm

Internal: 523 x 46 x 670 mm

**Refrigerant**

R 407C

**Refrigerant content**

See type plate on unit

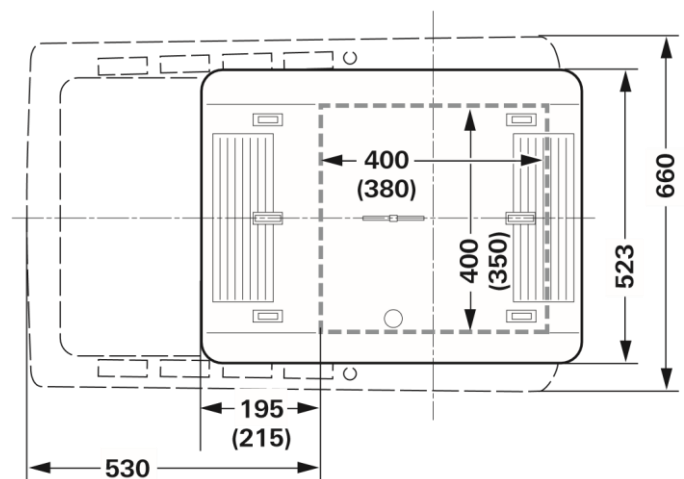
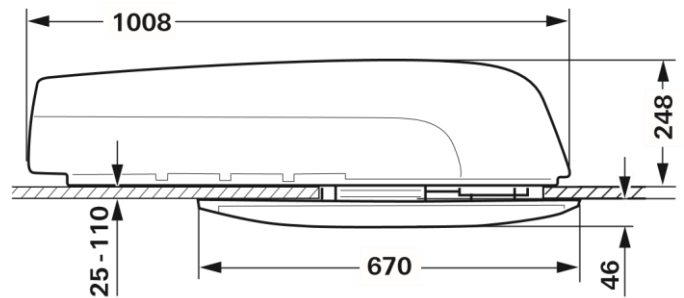

Installation dimensions (dimensions in mm)



## Clearance around the air conditioning system

The clearances around the external unit must be 20 mm at the front, 100 mm to the side and as far as possible and not less than 200 mm to the rear.

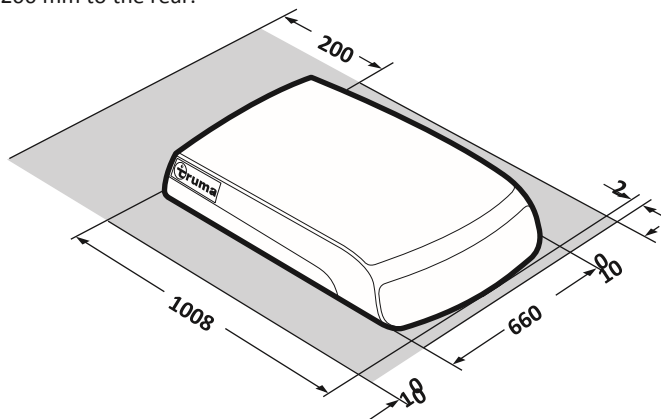

The clearance around the **air distributor** must ensure that air can escape unrestricted. There must be a clearance of at least 40 mm to the side. The swivel range of flaps and doors must be taken into account.

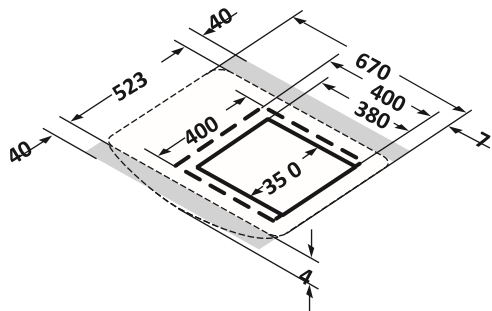

## Air inlets / Air outlets

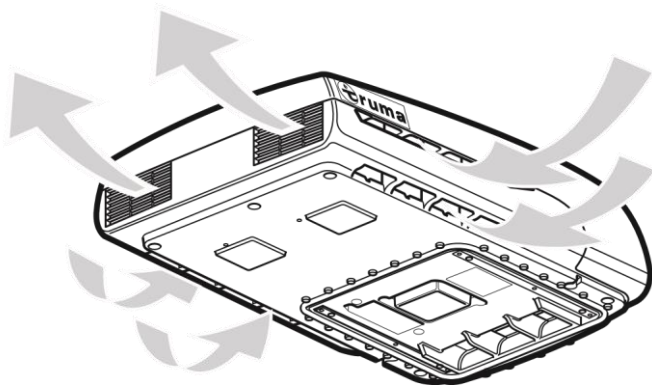

## Condensation traps

The condensation is led away over the roof of the vehicle.

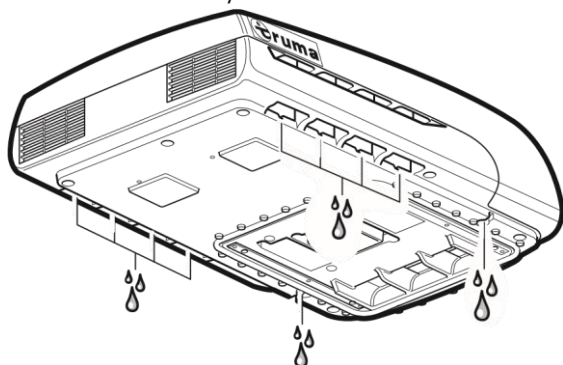

The right to effect technical modifications is reserved!

## Declaration of conformity

### 1. Information about the manufacturer

Name: Truma Gerätetechnik GmbH & Co. KG  
Address: Wernher-von-Braun-Str. 12, D-85640 Putzbrunn

### 2. Device identification

Type/Model:

**Aventa comfort** air conditioning unit

### 3. Meets the requirements of the following EC Directives

- 3.1 Electromagnetic Compatibility 2004/108/EC
- 3.2 Low Voltage Directive 2006/95/EC
- 3.3 Radio Interference in Vehicles 72/245/EEC  
(with the supplements)
- 3.4 End-Of-Life Vehicle Directive 2000/53/EC

and bears type approval numbers E24 10R-030696 and the CE symbol.

### 4. Basis of the conformity assessment

EN55014-1; EN61000-3-2; EN61000-3-3; EN62233;  
EN55014-2; IEC / EN60335-1; IEC / EN60335-2-40; 2009/19/EC; DIN  
EN378-2

### 5. Information and the function of the signatory

Signature: Dr. Schmall  
Managing Director / Engineering

Putzbrunn, 18/02/2011

## Truma warranty policy

The warranty is given by Dometic Pty Ltd, Building 3B, Clayton Business Park, 1508 Centre Road, Clayton, Victoria, 3168, for 12 months from the date of purchase against any defect arising from faulty materials or workmanship.

Repairs will be carried out during normal business hours only by Dometic Pty Ltd, or its duly authorised service agents, and are subject to the warranty conditions and exclusions hereunder.

## Warranty conditions

- The company will only provide service on presentation of proof of purchase, on either the Truma product, or the Caravan / RV / Pleasure Craft in which the Truma product has been installed, to any authorised service agent. The purchaser must allow the service agent to photocopy the proof of purchase to facilitate his claim to the manufacturer.
- Warranty repairs can only be performed by authorised service agents and under no circumstances will Dometic reimburse repairs carried out by unauthorised persons. Tampering with any part of the product by unauthorised personnel will automatically void the warranty.
- The product must be used solely for domestic purposes only. If the product is used for commercial purposes the warranty is 6 months only.
- Where applicable, the products must be used on the appropriate electrical voltage, gas type and pressure, or fuel source.



- If at any time during the warranty period any part or parts are replaced with a part or parts not supplied or approved by Truma, this warranty shall immediately become void.

## Important notice

Before calling a service technician please check carefully the operating instructions, service booklet and warranty terms and conditions. If the product fails for any of the reasons detailed therein, or is faulty due to abuse, misuse or improper installation, then a service fee shall be charged to the purchaser.

If you have any queries regarding the interpretation of the warranty you should contact Dometic Pty Ltd.

Whilst this book represents service outlets at the time of printing, changes occur from time to time. Should you have any queries or wish to locate your nearest authorised service agent please contact Dometic Pty Ltd.

## Warranty does not cover

- Any appliance which has been:
  - (a) Subject to misuse, neglect, accident or alteration by any person.
  - (b) Damaged or destroyed by fire, flood, act of God or other inevitable accident.
- Fair wear and tear.
- Damage from foreign substances such as dirt or liquid.
- Travelling expenses or call out fee to and from authorised service agents premises.
- Accommodation or Site Expenses.
- Cleaning of the system. This is considered to be a part of normal product maintenance.
- Non operation of the appliance or resultant damage to the unit where the appliance has been operated in an out of level situation.
- Freight cost of the appliance or parts, to or from, point of service or transit damage.
- Dometic / Truma are not responsible for resultant loss or damage sustained by the purchaser.
- Non operation of the appliance or resultant damage to the unit where the appliance has not been installed, ventilated, flued or operated in accordance with the manufacturers instructions.

Apart from any warranties implied by the Trade Practices Act 1974 or any relevant State legislation all other warranties express or implied whether arising by virtue of statute or otherwise are hereby excluded.

## Installation instructions



Installation and repair of the device may only be carried out by properly qualified professionals. Before starting work, read the installation instructions thoroughly and follow them carefully!

## Scope of delivery

### External unit:

- 1 Aventa comfort
- 2 brackets
- 4 screws, M6 x 70, coated with sealant
- 6 screws, M6 x 12, coated with sealant

- 1 roof thickness adapter (base ring)
- 2 roof thickness adapters (each 10 mm)
- 1 remote control with mounting
- 2 screws 2.9 x 16 for mounting
- 2 batteries, type AAA
- 1 set of instructions for installation and use
- 1 installation template
- 3 Wago terminals

### Air distributor:

- 1 air distributor, fully assembled

## Intended use

This unit was designed for installing in motor homes and caravans. It is intended for domestic use. Any other applications are only possible after consultation with Truma.

## Location selection

The vehicle roof (roof thicknesses from 25 to 110 mm) must be level and smooth.

There are 3 installation options:

- A new cut-out has to be made (350 x 380 mm)
- Cut-out from an existing skylight (400 x 400 mm) **without** sealing frame (accessories)
- Cut-out from an existing skylight (400 x 400 mm) **with** sealing frame (accessories) (Operating instructions are supplied with the sealing frame.)

### Please always take the following requirements into account:

- If at all possible, the unit should only be installed a little way from the centre of the vehicle.
- Check that installation will not be obstructed in any way.
- There may be electrical cables running between the inside and the outside of the roof. Disconnect all voltage sources before starting work (all poles).
- The maximum permitted roof load must not be exceeded (see the vehicle manufacturer's specification).
- Check the internal installation location for obstructions.
- A wooden reinforcement frame must be fitted around the cut-out in the roof between the upper and lower roof surface (min. 25 mm). It may be necessary to remove the insulation.

## Installation in a 400 x 400 cut-out

For optimum sealing, we recommend using the sealing frame which can be purchased as an accessory (part no. 40091-19000).

Installation with the sealing frame is described in the installation instructions supplied with it.

Installation of the unit in vehicles **with** an existing skylight: The cut-out must measure 400 x 400 mm.

Remove the existing skylight (increase the size of the cut-out if necessary).

Remove seal residue and unevenness.

Fill screw holes with body sealant.

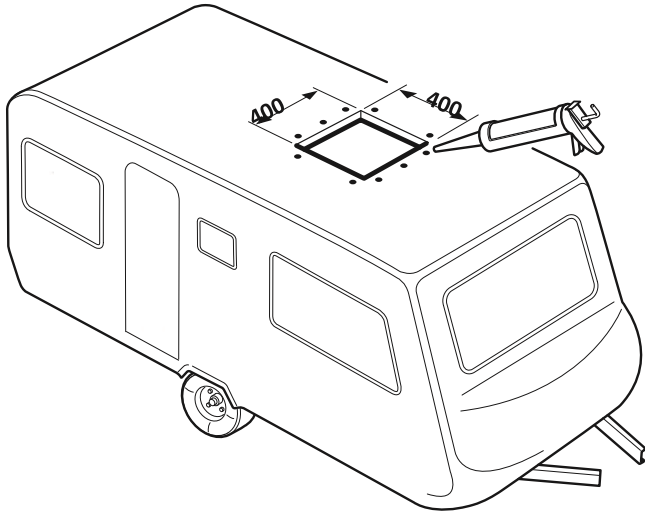

For the remaining installation steps, please refer to „Preparation for mains cable connection“.

### Installation in a new cut-out

Vehicles without an existing cut-out: required cut-out 350 x 380 mm

Place the template in the installation location on the vehicle and mark and cut out the cut-out (350 x 380 mm).

Mark out the 4 holes (10 mm) for attaching the brackets and drill through the roof.

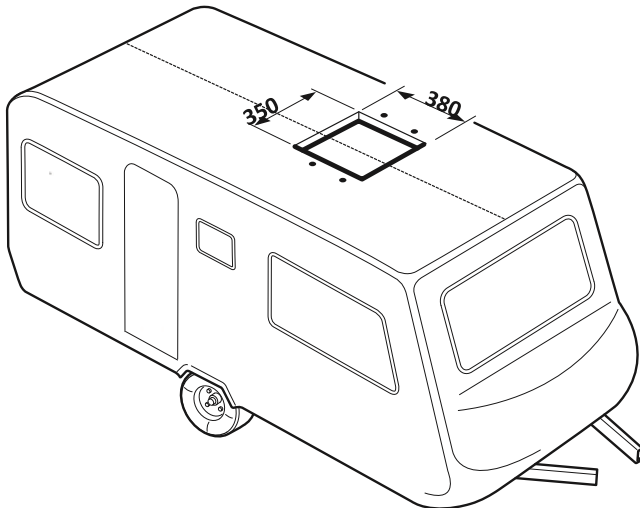

### Preparation for mains cable connection

A leadthrough for the mains cable to the connection point should be provided in the intermediate ceiling, for example.

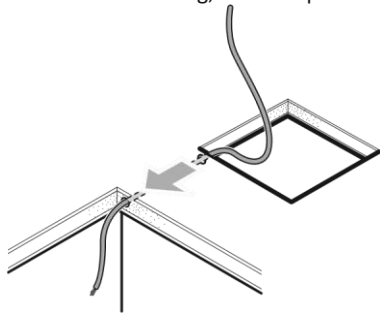

Lift the unit onto the roof, holding it in a horizontal position, and insert it into the cut-out. The arrow points in the vehicle's direction of travel.

If the unit has been turned over or was not horizontal at all times, you must wait 2 hours before switching it on.

Slide the unit forward in the cut-out as far as it will go.

Remove the protective film.

Route the power supply cable to the connection point (extend the cable with however many Wago terminals you need if necessary).



### Fixing the unit in place

Screw the two brackets (marked with an arrow pointing in the vehicle's direction of travel) to the unit using the 4 M6 x 70 screws (with sealant) included in the scope of supply (tightening torque 1.8 Nm).

M6 screws must be used for roof thicknesses of more than 50 mm (length = roof thickness + 30 mm) and tensile strength of 8.8. The screws must be coated with low-strength sealant (e.g. Loctite).

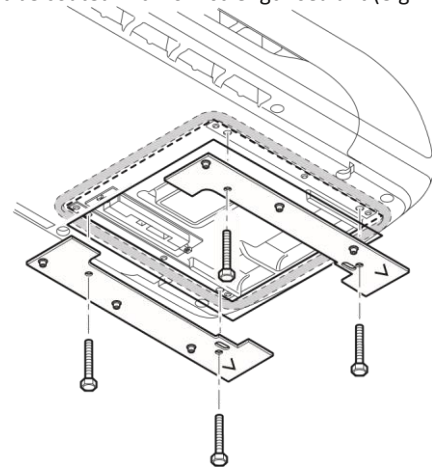

### Installing roof thickness adapters

Dependent upon the roof thickness, slide a roof thickness adapter (roof thickness adapter (base ring) and 10 mm roof thickness adapter for roof thickness from 25 to 50 mm) into the air distributor as far as the stop. Use additional 10 mm roof thickness adapters (see accessories) if the roof is thicker. Maximum roof thickness 110 mm.

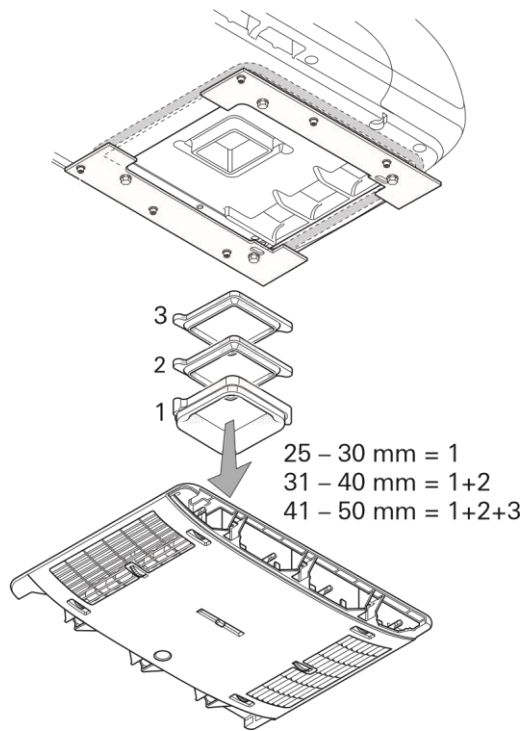

### Fixing the air distributor in place

Connect the cable from the air distributor to the electronics box.

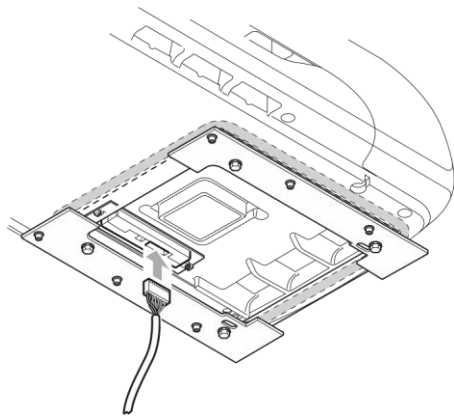

Screw the air distributor (arrow pointing in the vehicle's direction of travel) to the brackets with 6 screws M6 x 12 mm.

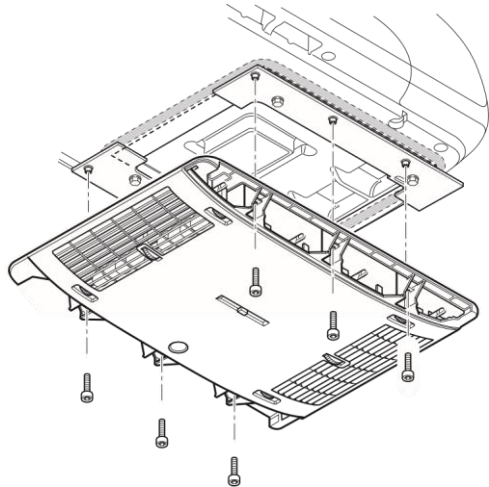

### Installing filters

Insert the filters in the panels and connect them to the air distributor.

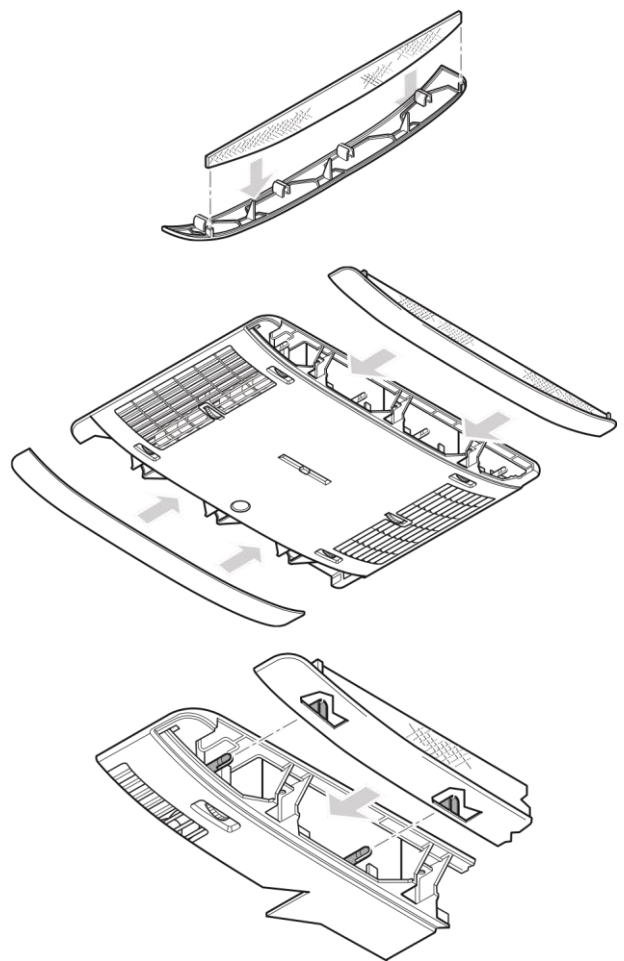

### 230 V electrical connection



The 230 V electrical connection must always be made by an expert (in accordance with VDE 0100, part 721 or IEC 60364-7-721, for example, in Germany). The information given here is not intended as instructions for you to carry out. It is for assisting the expert assigned to carry out the job, acting as auxiliary information when connecting the appliance!

Connect the power supply cable that has been routed to the connecting point.

All cables must be secured with clamps!

For maintenance or repair work, an isolating device must be provided on the vehicle side to provide all-pole isolation from the mains, with a contact interval of at least 3.5 mm.

### Function test / Mounting for the remote control

Install the mounting for the remote control in the required location.

All device functions must then be tested as described in the operating instructions.

Once the unit has been installed, the person completing the installation must check that the condensation traps are not obstructed.

The operating instructions must be handed to the owner of the vehicle.



In Australia, always notify the Dometic Service Centre if problems are encountered; in other countries the relevant service partners should be contacted (see Service Booklet or [www.truma.com](http://www.truma.com)).

Having the equipment model and the serial number ready (see type plate) will speed up processing.

Dometic Pty Ltd  
Building 3B,  
Clayton Business Park  
1508 Centre Road  
Clayton, Victoria, 3168  
Australia

**Service (Australia)**

Telephone: +61 (0)3 92 39 10 00  
Facsimile: +61 (0)3 92 39 10 99

Dometic New Zealand Ltd. 26  
Cashew Street,  
Grenada North Wellington  
New Zealand

**Service (New Zealand)**

Telephone +64 (0)4 232 38 98  
Facsimile +64 (0)4 232 38 78